



NOTES:

1. MATERIAL:
 - 1.1 HOUSING: High Temperature Thermal Plastic .
 - 1.2 CONTACT: COPPER ALLOY.
2. FINISH:
 - 1: Gold Flash
 - N: 80~120u"Matt Tin(Lead Free)
3. REFLOW SOLDER CAPABLE TO 260°C PER ACES SPEC.
4. Applicable wire:
 - AWG #32/7C, UL1867 OD:0.38±0.02mm.
 - WIRE RETENTION FORCE PLS REFER TO SPEC
5. SPEC. PLS. REFER TO PS-50208-xxxxx
6. PART NUMBER

P/N LEGEND

50375-XXX X X - XXX

NO OF CKT

PACKING
1: TUBE
3: BAG

XXX	SHAPE	LOGO	COLOR	Halogen Free
001	NONE	YES	BLACK	HF
002	YES	YES	BLACK	HF

Plating
1: Gold Flash
N: 80~120u"Matt Tin(Lead Free)

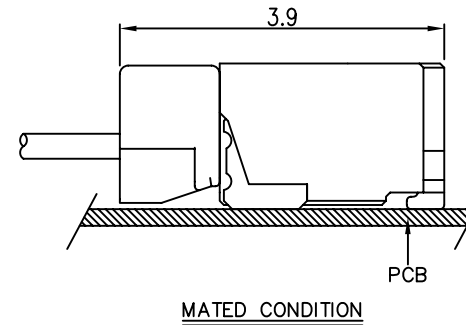
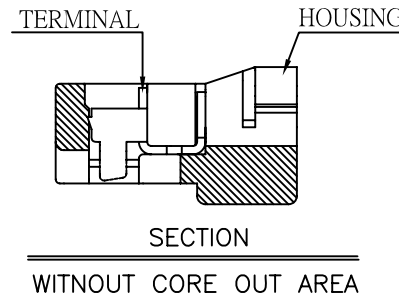
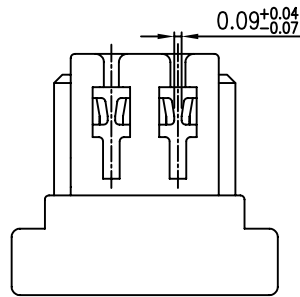
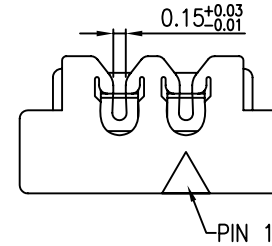
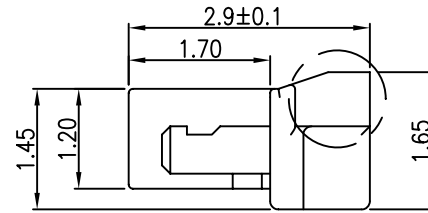
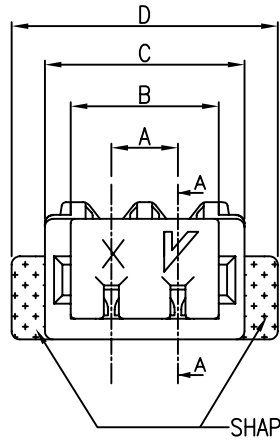

CKT.	Dim A	Dim B	Dim C	Dim D
2	0.80	1.78	2.40	3.20
3	1.60	2.58	3.20	4.00
4	2.40	3.38	4.00	4.80
5	3.20	4.18	4.80	5.60
6	4.00	4.98	5.60	6.40
7	4.80	5.78	6.40	7.20
8	5.60	6.58	7.20	8.00
9	6.40	7.38	8.00	8.80
10	7.20	8.18	8.80	9.60
11	8.00	8.98	9.60	10.40
12	8.80	9.78	10.40	11.20
13	9.60	10.58	11.20	12.00
14	10.40	11.38	12.00	12.80
15	11.20	12.18	12.80	13.60
16	12.00	12.98	13.60	14.40
17	12.80	13.78	14.40	15.20
18	13.60	14.58	15.20	16.00
22	16.80	17.78	18.40	19.20

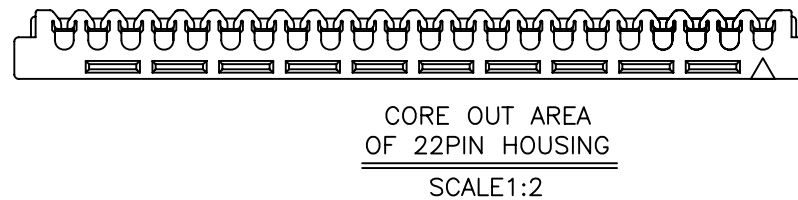
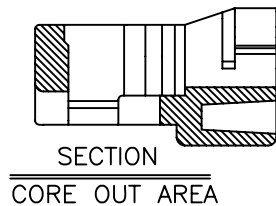

一般公差 TOLERANCES X ±0.5 XX ±0.15 X ±0.25 XXX ±0.1 ANGLES ±2°		宏致電子股份有限公司 Aces Electronic Co.,Ltd.	
檢驗尺寸標示 SYMBOLS ⊕ ⊗ INDICATE CLASSIFICATION DIMENSION ⊕ MARK IS CRITICAL DIM. ⊗ MARK IS MAJOR DIM.	品名 (TITLE) 0.8mm Pitch WTB CONN.	製圖 (DR) '12/02/27 XUBIN 審核 (CHKD) SAM	圖號 (DWG.NO) 50375-XXXXX-XXX
表面處理 (FINISH)	比例 (SCALE) 單位 (UNITS) 1:1 mm	核准 (APPD) JASON	張數 (SHEET) 1 OF 1 SIZE A4 REV E



A B C D E F

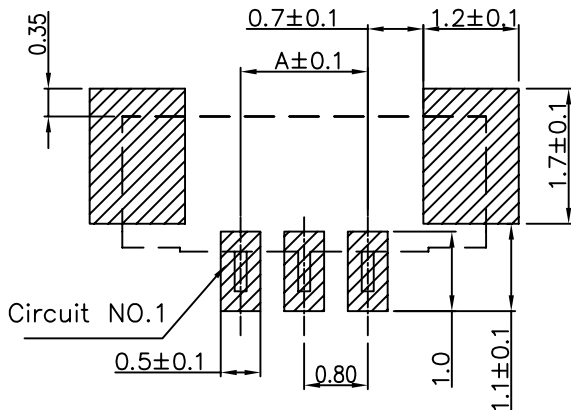
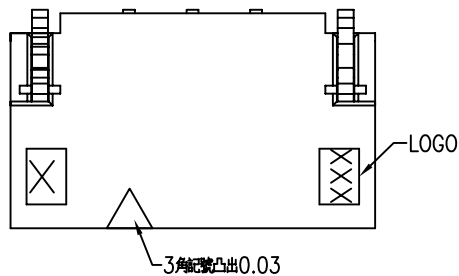

PCB LAYOUT

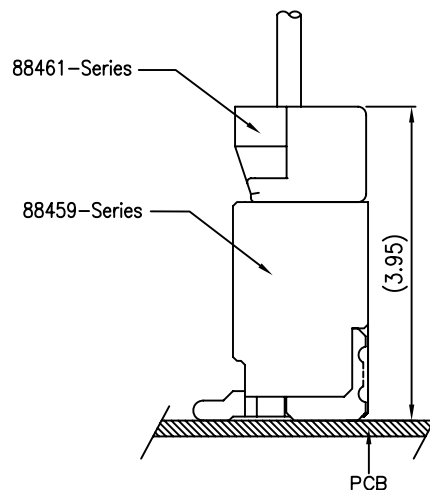
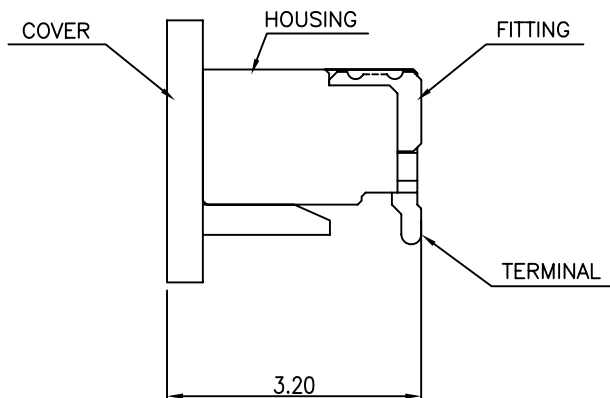
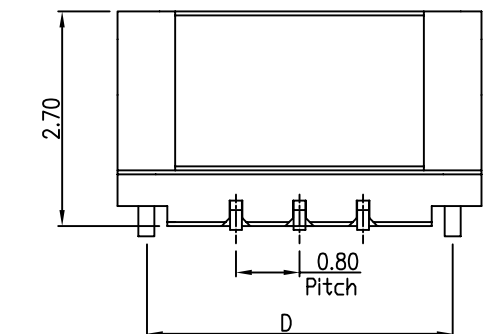
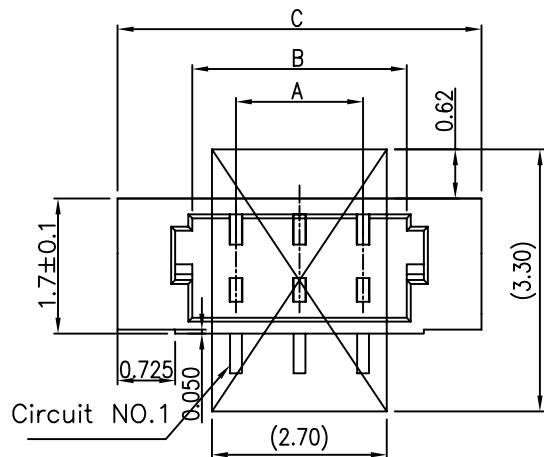

MATE DRAWING

NOTES:

1.MATERIAL:

HOUSING: Halogen Free PLASTIC, HIGH TEMP. UL94V-0
 TERMINAL: PHOSPER BRONZE (t=0.15)
 FITTING NAIL: BRASS (t=0.2)

2.PLATING:

UNDERPLATING: 50u" MIN. NICKEL OVERALL.
 1: GOLD FLASH OVER ALL
 8: 4U" GOLD ON CONTACT AREA
 N: 100~200u" MATT TIN OVERALL

3.SPECIFICATION PLS. SEE PS-50208-XXXX

4.PACKING REFER TO 88459-XXXX-TRP

P/N LEGEND

50207-XXX X X-XXX-XX

NO OF CKT

PACKING
 7: TAPE & REEL
 (WITH COVER)
 8: TUBE (WITH COVER)

PLATING

1: GOLD FLASH OVER ALL (LEAD FREE)

XXX-XX	COLOR	LOGO	Halogen Free	Pitch of Packing
001-□	BLACK	ACES	HF	N/A
P01-□	BLACK	ACES	HF	12.00mm

CKT	Dim A	Dim B	Dim C	Dim D
2	0.80	1.90	3.78	3.04
3	1.60	2.70	4.58	3.84
4	2.40	3.50	5.38	4.64
5	3.20	4.30	6.18	5.44
6	4.00	5.10	6.98	6.24
7	4.80	5.90	7.78	7.04
8	5.60	6.70	8.58	7.84
9	6.40	7.50	9.38	8.64
10	7.20	8.30	10.18	9.44
11	8.00	9.10	10.98	10.24
12	8.80	9.90	11.78	11.04
13	9.60	10.70	12.58	11.84
14	10.40	11.50	13.38	12.64
15	11.20	12.30	14.18	13.44
16	12.00	13.10	14.98	14.24
17	12.80	13.90	15.78	15.04
18	13.60	14.70	16.58	15.84
19	14.40	15.50	17.38	16.64
20	15.20	16.30	18.18	17.44

一般公差
TOLERANCES
 X ±0.5 XX ±0.15
 X ±0.25 XXX ±0.1
ANGLES ±2°

檢驗尺寸標示
SYMBOLS (M) (L) INDICATE
CLASSIFICATION DIMENSION

(M) MARK IS CRITICAL DIM.
 (L) MARK IS MAJOR DIM.

表面處理 (FINISH)

宏致電子股份有限公司
Aces Electronic Co.,Ltd.

品名 (TITLE)
 0.8mm Pitch WTB Header
 SMT S/T TYPE

製圖 (DR) LZ
 10/07/13
 審核 (CHKD) CARL
 核准 (APPD) Jason

圖號 (DWG.NO)
 50207-XXXXX-XXX-XX

比例 (SCALE) 單位 (UNITS)
 5:1 mm

張數 (SHEET) 1 OF 1
 尺寸 (SIZE) A4
 版本 (REV) B

A B C D E F