



# 产品规格书

PRODUCT SPECIFICATION

客户名称Buyer Name	
客户料号Buyer Part No.	
客户承认签章 Buyers Approval & Signatures	

文件编号Spec No.		版本	A/1
品名描述 Product Description	圆柱直流马达 Cylindrical DC motor		
型号Part No.	VZ30C1B839981		
送样日期Date			
设计Designed by	审核Checked by	批准Approved by	
2020.07.01	2020.07.01	2020.07.01	

www.vybronic.com  
sales@vybronic.com

**Records of Revision**

Rev. No.	Rev. Date	Page No.	Revised Item	Reason
A/0	2017.5.25	/	产品颁布/ Release for Production	
A/1	2020.07.01	/	changed company name from JINLONG MACHINERY to VYBRONICS, changed part # from Z30C1B839981 to VZ30C1B839981	Rebranding

## Preface:

Thank you very much for your selecting the Vybronic VZ30C1B839981 vibrator. Our products have stable performance. To obtain maximum performance from the product, please read this specification first, and keep it handy for future reference.

## TABLE OF CONTENTS

<b>SECTION</b>	<b>DESCRIPTION</b>	<b>PAGE#</b>
1. SCOPE.....		5
2. MECHANICAL CHARACTERISTIC.....		5
3. ELECTRICAL CHARACTERISTICS.....		5
4. ADDITIONAL INFORMATION.....		6
5. CRITICAL CHARACTERISTICS.....		6
6. ENVIRONMENTAL CHARACTERISTICS.....		6
7. RELIABILITY TESTS.....		6
8. VIBRA DRIVER REQUIREMENTS FOR OPERATIONAL TESTS.....		9
9. QUALITY ASSURANCE.....		9
10. MATERIALS.....		9
11. PACKAGING CONDITION .....		10
12. RECOMMENDED REFLOW PROFILE FOR VIBRATOR.....		13
13. NOTES ON USE.....		14
APPENDIX 1 .....		15
APPENDIX 2 .....		16

## 1. SCOPE

This document contains specific electrical and mechanical characters, critical characteristics, reliability tests, packaging condition, quality assurance, reflow profile and etc..

## 2. MECHANICAL CHARACTERISTIC

- |   |                       |
|---|-----------------------|
| 2.1. Mechanical drawing   | See appendix 2        |
| 2.2. Axial play of shaft  | 0.3 mm Max            |
| 2.3. Counter weight density:  | 17.0 g / cc Min       |
| 2.4. Mechanical noise of motor operating at rated speed:                    | 45 dB Max A-weighting |
| Background noise 26dB.(Measured distance 10 cm, see appendix 1 Figure 1.1). |                       |

## 3. ELECTRICAL CHARACTERISTICS

- |  |                                       |
|--|---------------------------------------|
| 3.1. Vibrator positioning:   | Horizontal                            |
| 3.2. Operating voltage:  | 3.0 V                                 |
| 3.3. Operating voltage range:  | 2.3– 3.6V                             |
| 3.4. Load current at operating voltage:  | 85 mA Max                             |
| 3.5. Starting current at operating voltage:  | 100 mA Max                            |
| 3.6. Insulation resistance and voltage break down:   | at 100V DC, 1M $\Omega$ Min and above |
| 3.7. Terminal resistance:  | 30.0 $\pm$ 5.0 $\Omega$               |
| 3.8. Load speed:   | 12000 $\pm$ 2500 rpm                  |
| 3.9. Rotation direction:   | C.W. & C.C.W                          |
| 3.10. Motor vibration Force:   | 0.20 G Min                            |
| (The G-force is 0.20G min when the motor is under the loading of 100g at rated voltage, see appendix 1 Figure 1.2) |                                       |
| 3.11. Rise time (see picture 1)  | 100 ms Max                            |
| 3.12. Rree Fall time (see picture 1)   | 70 ms Max                             |
| -From zero to 90% of nominal speed   |                                       |
| -From nominal velocity to 10% of nominal speed   |                                       |

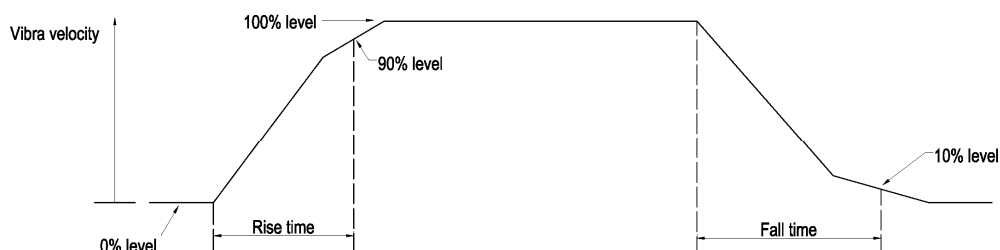

Picture 1 RPM rise and fall time

- 3.13 Standard loaded starting voltage: Under standard loaded condition, towards C.W. rotor shall

move in all position at 2.3V (counterweight should be turned slowly at 360°)

All mechanical and electrical measurements should be measured at room temperature and ordinary humidity.

#### 4. ADDITIONAL INFORMATION

- 4.1. Vibrator weight 0.75g
- 4.2. Pull out strength of counter weight and shaft 30N Min
- 4.3. Acceleration level at nominal RPM (Grms) (test jig mounted in freely suspended)
- 4.4. Speed and current variation (function of temperature, -20°C to +70°C)

#### 5. CRITICAL CHARACTERISTICS

- 5.1. Functional dimensions
- 5.2. Rated current at specified rotating speed
- 5.3. Operating speed at operating voltage
- 5.4. Starting current at operating voltage
- 5.5. Min. starting Voltage

#### 6. ENVIRONMENTAL CHARACTERISTICS

- 6.1. Operating temperature ranges: -20°C to +70°C
- 6.2. Storage temperature ranges: -40°C to +85°C

#### 7. RELIABILITY TESTS

7.1 We have already performed reliability tests and measure nom rotation speed, nom load current, nom resistance, nom starting currents and nom starting voltage before and after tests, please check following table1 for detail reliability test information. Each test we use at least 10 samples for verification.

	Items	Test conditions	Judgment
7.2	Low temperature storage test	Storage test -40±3°C/96h, recovery 1~2h Measurements with test jig.	No mechanical damage. Normal performance of vibrator. (Max +/-30% variation of nom RPM)

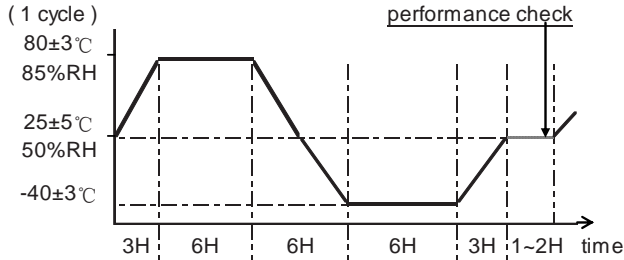
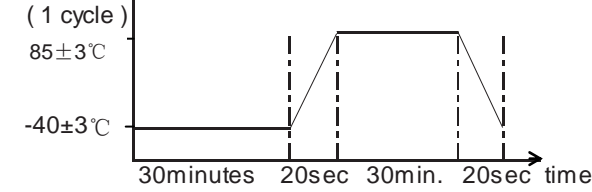
7.3	High temperature storage test	<p>Storage test  <math>80\pm 3^{\circ}\text{C}/96\text{h}</math>, recovery 1~2h                      Measurements with test jig.</p>	<p>No mechanical damage.                      Normal performance of vibrator.                      (Max +/-30% variation of nom RPM)</p>
7.4	Temperature cyclic test	<p>Storage test                      Temperature &amp; humidity: <math>+80\pm 3^{\circ}\text{C}/6\text{h}(\text{RH}85\%)</math>;  <math>-40\pm 3^{\circ}\text{C}/6\text{h}</math> with 6h maximum transition time between temperatures. 24h/cycles, totally 6 cycles.                      Recovery 1~2h. Performance check daily.                      Measurements with test jig.</p>  <p>(1 cycle)  <math>80\pm 3^{\circ}\text{C}</math>  <math>85\% \text{RH}</math>  <math>25\pm 5^{\circ}\text{C}</math>  <math>50\% \text{RH}</math>  <math>-40\pm 3^{\circ}\text{C}</math></p> <p>3H 6H 6H 6H 3H 1~2H time</p> <p>performance check</p>	<p>No mechanical damage.                      Reduced performance of vibrator.                      (Max +/-30% variation of nom RPM)</p>
7.5	Thermal shock test	<p>Storage test                      Temperature &amp; humidity: <math>-40\pm 3^{\circ}\text{C}/30\text{minutes}</math>;  <math>+85\pm 3^{\circ}\text{C}/30\text{minutes}</math> with a 20sec maximum transition time between temperatures.                      1h/cycle, totally 50 cycles.                      Recovery 1~2h. Measurements with test jig.</p>  <p>(1 cycle)  <math>85\pm 3^{\circ}\text{C}</math>  <math>-40\pm 3^{\circ}\text{C}</math></p> <p>30minutes 20sec 30min. 20sec time</p>	<p>No mechanical damage.                      Normal performance of vibrator.                      (Max +/-30% variation of nom RPM)</p>
7.6	Room temperature lifetime test	<p>Operational test: apply operating voltage                      Temperature &amp; humidity: <math>25\pm 3^{\circ}\text{C}</math>, RH 50%                      On/off time: 2.5s on/off, 300,000 cycles.                      Performance check: before, after test and every 20,000 cycles.                      Recovery 1-2h. Measurements with test jig.</p>	<p>No mechanical damage.  <u>After 100,000cycles:</u>                      Normal performance of vibrator. (Max +/-30% variation of nom RPM)  <u>After 300,000cycles:</u>                      The vibrator should operate.</p>

7.7	High temperature lifetime test	Operational test: apply operating voltage Temperature : 55±3°C On/off time: 2.5s on/off, 53,000 cycles. Performance check: before, after test and every 20,000 cycles. Recovery 1~2h. Measurements with test jig.	No mechanical damage. Normal performance of vibrator. (Max +/-30% variation of nom RPM)												
7.8	Low temperature lifetime test	Operational test: apply operating voltage Temperature : -20±3°C On/off time:2.5s on/off, 53,000 cycles. Performance check: before, after test and every 20,000 cycles. Recovery 1~2h. Measurements with test jig.	No mechanical damage. Normal performance of vibrator. (Max +/-30% variation of nom RPM)												
7.9	H <sub>2</sub> S corrosion test	Storage test Concentration: 3±1ppm Temperature & humidity: 40±3°C, RH 80% Exposure time: 24hours	No mechanical damage. Normal performance of vibrator. (Max +/-30% variation of nom RPM)												
7.10	Free Fall	Mount the vibrator in the dummy box.(dummy box weight 100g), Drop height 1.5 m onto concrete. 3 times in each 6 directions. Measurements with test jig.	No mechanical damage. Normal performance of vibrator. (Max +/-30% variation of nom RPM)												
7.11	Random vibration test	<table border="1"> <tr> <td colspan="2">3axes, 10minutes per axis, 6.06Grms</td> </tr> <tr> <td>Frequency (Hz)</td> <td>A.S.D.(G<sup>2</sup>/Hz)</td> </tr> <tr> <td>20</td> <td>0.0098</td> </tr> <tr> <td>80</td> <td>0.04</td> </tr> <tr> <td>350</td> <td>0.04</td> </tr> <tr> <td>2000</td> <td>0.0069</td> </tr> </table> Measurements with test jig.	3axes, 10minutes per axis, 6.06Grms		Frequency (Hz)	A.S.D.(G <sup>2</sup> /Hz)	20	0.0098	80	0.04	350	0.04	2000	0.0069	No mechanical damage. Normal performance of vibrator. (Max +/-30% variation of nom RPM)
3axes, 10minutes per axis, 6.06Grms															
Frequency (Hz)	A.S.D.(G <sup>2</sup> /Hz)														
20	0.0098														
80	0.04														
350	0.04														
2000	0.0069														
7.12	Shock test	Time of test and direction: 3times in each 6 direction. Total 18 times. Acceleration: Half-sinusoidal 500G Duration:2ms	No mechanical damage. Normal performance of vibrator. (Max +/-30% variation of nom RPM)												

**Table1 Reliability test**



**8. EXPECTED SHIPPING AND STORAGE CONDITIONS**

8.1. Relative humidity	15%~70%
8.2. Temperature	-5°C~40°C
8.3. Sulphur dioxide average	0.3 mg/m <sup>3</sup>
8.4. Sulphuretted hydrogen average	0.1 mg/ m <sup>3</sup>
8.5. Storage period	12 months

(Vibrator has to be rotated at least once within 12 months from the date of receipt)

**9. QUALITY ASSURANCE**

All critical parameters are 100% in control. The symbols “◆” apply to all parameters identified as critical parameters in all process. And before mass production approval, we use Process Capability Study (PCS) to conduct all critical parameters in mass production. Based on PCS the final quality controls will be agreed.

Quality assurance for mass production:

- Lot acceptance rate (LAR)
- First pass yield (FPY)
- Outgoing quality level

Each final packing containing Out-going inspection data sheet (n=35pcs)

Inspection item: Load speed  
Load current  
Starting current  
Starting voltage  
Coil resistance

- Customer reject material rate
- Customer satisfaction
- Cpk/Cp control for all critical parameters (except starting voltage)

**10. MATERIALS**

- Counterweight
- Brush
- Commutator
- Case
- Terminal
- Bracket
- Washer
- End cover
- Bearing
- Magnet
- Copper wire
- Shaft
- Core
- Varistor

P.S.: All the materials included in vibrator can meet 2002/95/EC & Vybronic RoHS requirement

## 11. PACKAGING CONDITION

A detailed mechanical drawing for packing condition as followed with dimensions and tolerances:

### 12.1 Smallest packing

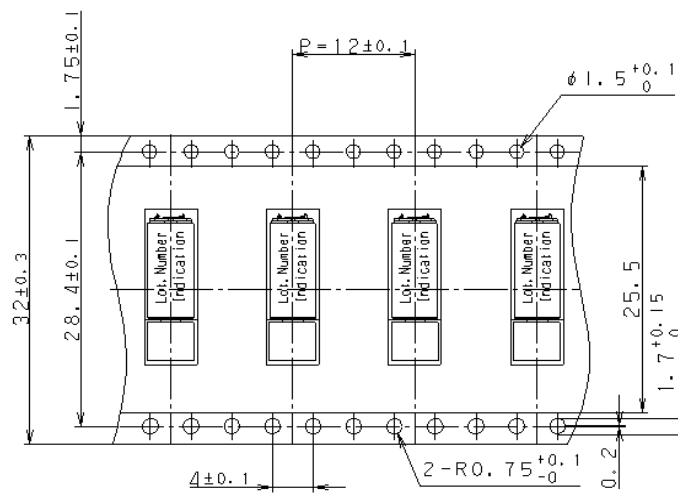

Picture 3 Smallest packing condition

11.2 Reel packing condition

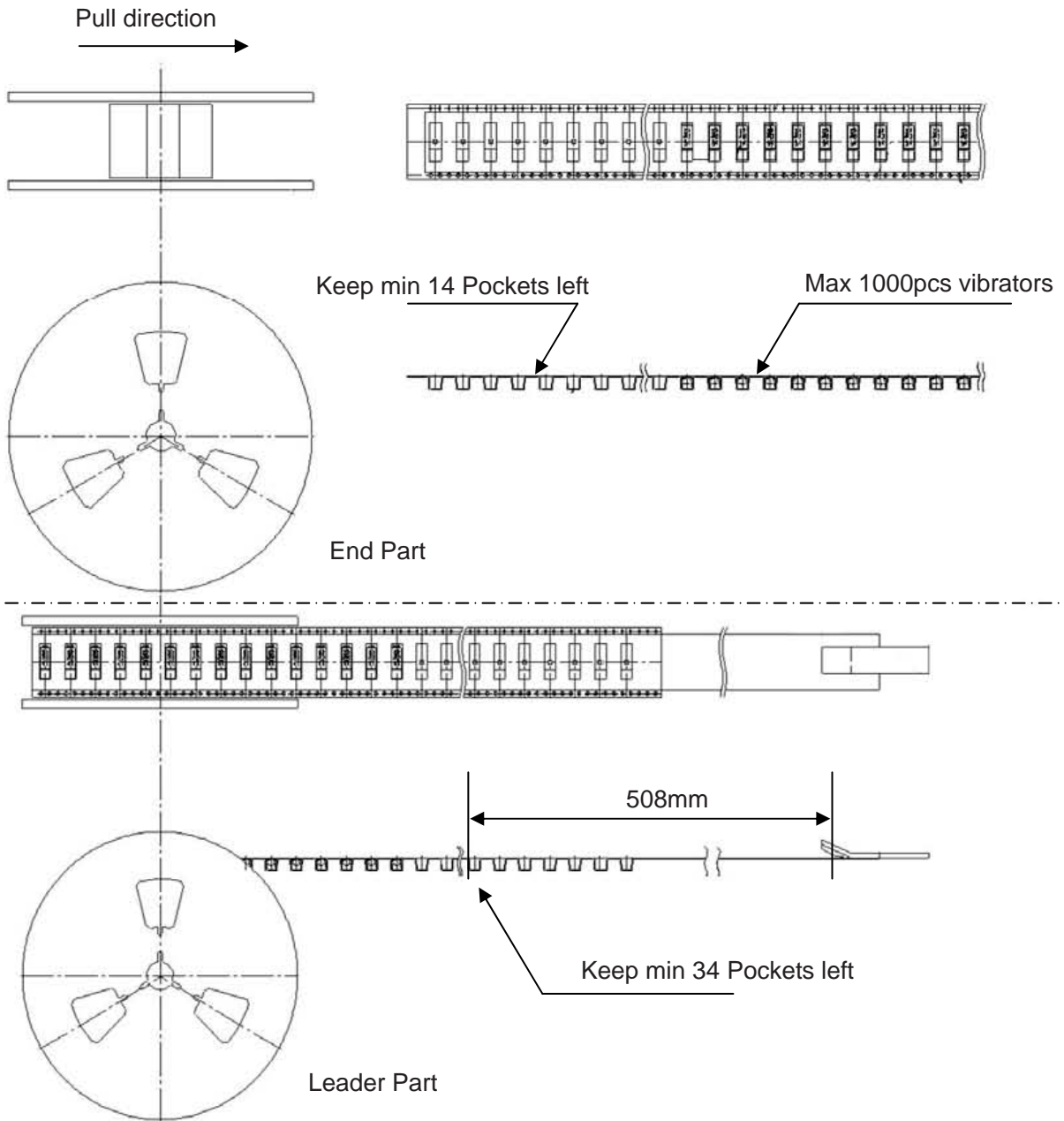

Picture 4 Reel packing condition

**11.3 Final packing condition**

1000pcs/reel X 6reel= total 6000pcs

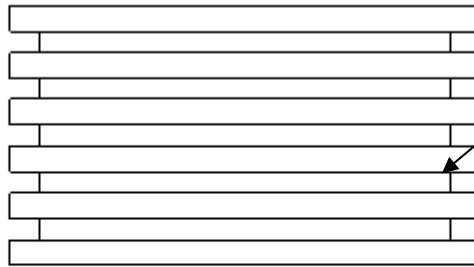

During the vibrator handle or shipping, counterweight must be faced to upper side.

Double wall corrugated cardboard

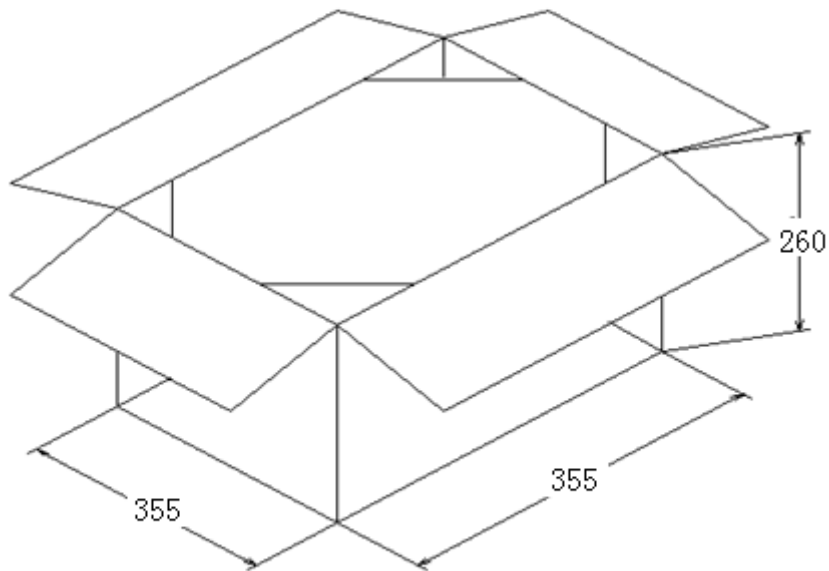

Picture 5 Final packing condition

**11.4 Accessories included in final package**

Out-going inspection data sheet (n=35pcs) will be attached for each lot, we do implemented inspection after reflow. Inspection item including:

- Load speed
- Load current
- Starting current
- Starting voltage
- Coil resistance

## 12. RECOMMENDED REFLOW PROFILE FOR VIBRATOR

### 12.1 Definitions

Reflow Profile = Time vs. temperature plot

Peak temperature = Maximum temperature reached on the component

Convection = Forced air heating

### 12.2 Recommended temperature check method of reflow furnace

The reflow furnace used should be 100% convection reflow. Thermocouples should be securely attached to the top surface of vibrator to insure the temperature exposure is met. Profile should be recorded by data acquisition for future reference.

### 12.3 Recommended reflow Profile for Pb-Free soldering

Temperature(°C)

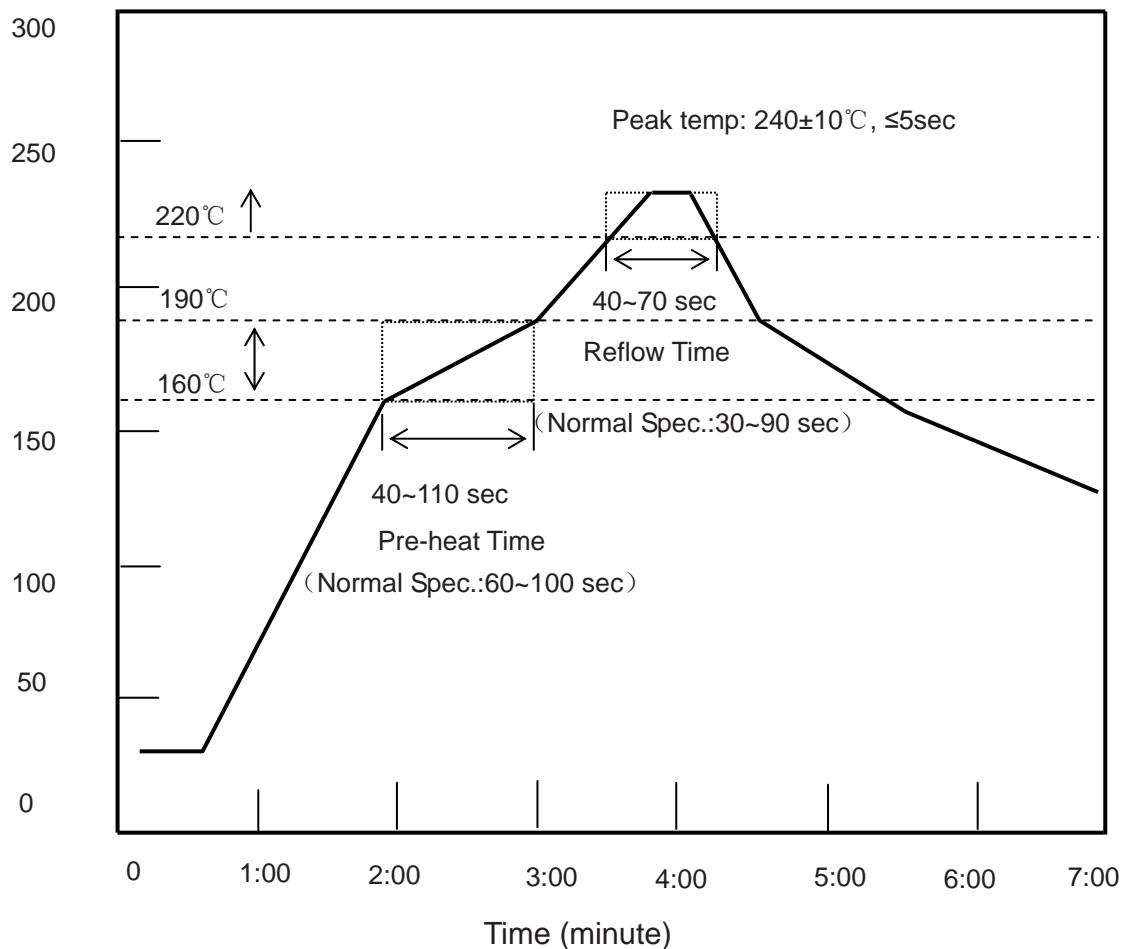

**13. NOTES ON USE**

- 13.1 Pay attention to the voltage and current ranges which applied to the vibrator, and use the vibrator in accordance with this specification, otherwise, it will reduce the life and performance of the vibrator.
- 13.2 Do not use hot gun to puff the surface of vibrator from PCB directly.
- 13.3 Do not locking the motor with current applied for long time, which may cause the motor to overheat and short circuit.
- 13.4 Do not exert pressure the terminals, otherwise, it will result in terminal deformation.
- 13.5 Do not bring magnetized objects near or contact with the surface of vibrator, which will demagnetize the magnetism of vibrator and result in noise failure.

**Appendix 1**

Figure 1.1: Mechanical noise measurements setup

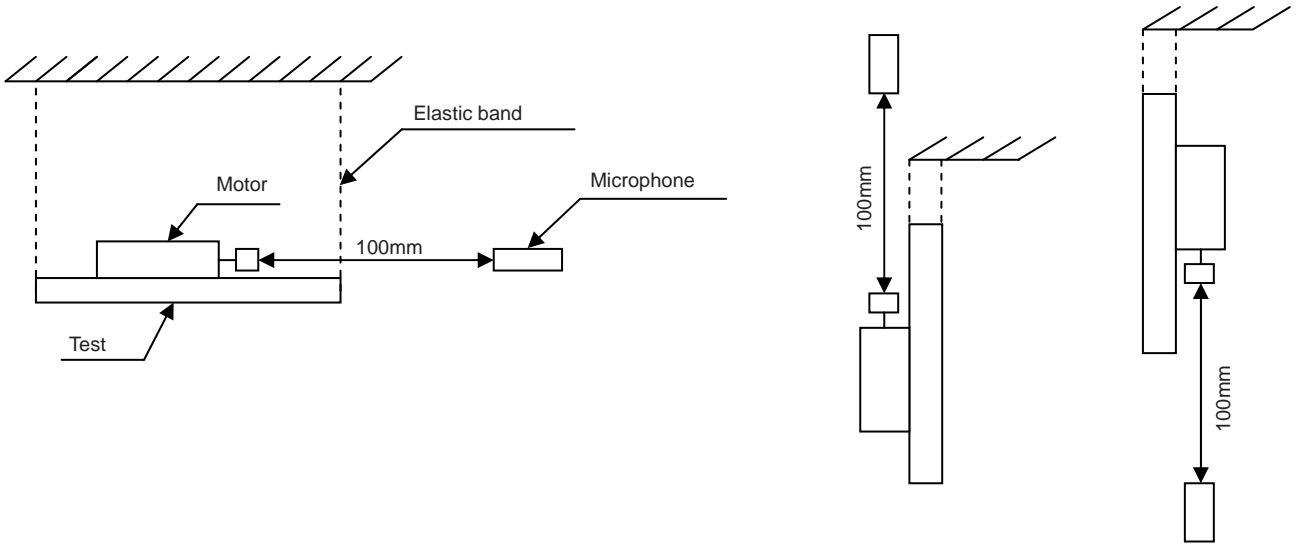

Figure 1.2: Test jig, weight 100g

