



产品规格书

PRODUCT SPECIFICATION

客户名称Buyer Name	
客户料号Buyer Part No.	
客户承认签章 Buyers Approval & Signatures	

文件编号Spec No.		版本	A/1
品名描述 Product Description	圆柱直流马达 Cylindrical DC motor		
型号Part No.	VZ30C1T8280002		
送样日期Date			
设计Designed by	审核Checked by	批准Approved by	
2020.07.01	2020.07.01	2020.07.01	

Vybronic

www.vybronic.com

info@vybronic.com

重要提示 IMPORTANCE NOTES:

1. 如对电机的性能和/或寿命有任何争议，仅基于此规格书作出判断。
If there is any argument on motor performance and/or life, judgment is to be made base on this specification only.
2. 客户方有责任确认该电机能满足您的使用要求。
Customer has the responsibility to ensure that the motor can satisfy the requirement of your application.
3. 如果贵公司未提供技术规格，该文件将详细叙述与贵公司商定的技术规格。
In the event that an official specification is not present by customer; this document will specify the agreed technical specification .
4. 在满足规格的条件下，我司可以改变零件材料、尺寸及形状来改善品质，和/或性能，和/或生产效率。
Within the limitation to satisfy this specification, Vybronic has the convenience to change the materials, sizes and shapes of components of the motor for the purpose of improving quality, and/or performance, and/or production efficiency.
5. 收到此规格书后，贵司应于下订单之前将规格书副本签回以示贵司已确认。如贵司未能在规定时间内签回副本，我司将认为贵司已收到并承认该规格书。
After the receipt of this specification, customer should send a signed copy to Vybronic before you issued purchase order for the confirmation on acknowledgement. Vybronic regard it as the receipt of this specification acknowledged if customer fails to return the confirmation to us within the described period.

更改记录 Revised Record

修改号 Rev. No.	日期 Rev. Date	页码 Page No.	修改项目 Revised Item	更改原因 Reason
A/0	2013.10.08	/	产品颁布/ Release for Production	
A/1	2020.07.01	/	changed company name from JINLONG MACHINERY to VYBRONICS, changed part # from Z30C1T8280002 to VZ30C1T8280002	Rebranding

1. 实用范围 Application

本说明书适用于圆柱铁芯马达 **VZ30C1T8280002** 型

This specification applies to Cylindrical core Motor **VZ30C1T8280002** model

2. 结构形式 Construction-form

序号 NO.	项目 Item	内容 Contents
2-1	电机结构 Motor construction	4mm×3mm的铁芯马达 4mm×3mm cylindrical core motor
2-2	磁极极数 Number of magnet poles	2 极(磁钢内置) 2-poles (inner magnet type)
2-3	换向方式 Rectifying method	金属电刷换向器装置 Metal brush and commutator

3. 标准使用条件 Standard operating condition

序号 NO.	项目 Item	规格 Specification	条件/备注 Condition / Remark
3-1	额定电压 Rated voltage	2.7V	加在端子两端的电压 Added to both ends of the terminal voltage
3-2	额定负荷 Rated load	振子 (R1.6 T=3.4) eccentric weight	振子重量约等于 0.27g eccentric weight is about equal to the weight of 0.27g.
3-3	旋转方向 Rotation direction	顺时针方向 CW	从输出端看, 并且电压正极接端子正极 When viewed from output side with +ve voltage applied to +ve terminal
3-4	摆放位置 Motor position	任意位置 Any position	
3-5	工作电压范围 Voltage range for use	DC 2.3V~3.2V	
3-6	使用环境 Operating conditions	-20℃~70℃ 0%~95%RH	常规湿度/ordinary humidity 不凝露/no condensation of moisture
3-7	贮存环境 Storage conditions	-40℃~85℃ 0%~95%RH	常规湿度/ordinary humidity 不凝露/no condensation of moisture/

4. 产品测试环境条件 Environmental Test Conditions

序号 NO.	项目 Item	测试环境条件 Environmental condition
4-1	温度 Temperature	20±2℃
4-2	湿度 Humidity	60±5% RH
4-3	电机体位 Motor Position	轴伸水平 Shaft Horizontal
4-4	电源 Power Supply	直流稳压电源/DC Power Supply DC2.7V±2%

备注: 所有的数据在温度 20±2℃, 湿度 60±5% RH的条件下测定。在对判定不发生异议时, 也可在温度 5~35℃, 湿度 45~85%RH的环境下测试。

NOTE: All data shall be based on the measurement under the temperature 20±2℃ and humidity 60±5% RH, however the range of temperature 5~35℃ and humidity 45~85%RH if there is no doubt about the judgment.

5. 机械特性 Mechanical Characteristic

序号 NO.	项目 Item	测试环境条件 Environmental condition	规格 Specification
5-1	外观尺寸 Configuration	游标卡尺 Vernier caliper	参考外形图纸 As specified in outline drawing
5-2	外观 Appearance	目测 Visual examination	无明显机械划痕、裂缝、锈迹、污点 No obvious evidence of mechanical damage、crack、rust and stain
5-3	重量 Weight	架盘天平 精度 0.1g Plate balance 0.1g	0.6g (Approx) (左右)
5-4	轴向间隙 Shaft end play	游标卡尺或百分表 Vernier caliper or Dial indicator	(0.05- 0.3) mm
5-5	振子固定力 Holding strength Of eccentric weight	测力计/Pulling force testing machine	50N (5.6kgf) Min

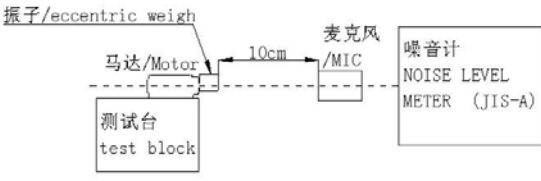
5-6	机械噪声 Mechanical Noise	 <p>测试场地：类半自由声场 额定电压，空载运行，背景噪声≤ 20 dB(A),电机固定在测试夹具上(轴伸水平)，拾音器沿轴向正对电机平面，距离 10 cm。 Test site: Class of semi-free field At rated voltage and free load, Back ground noise: 20 dB(A) Max, Fix the motor in a test jig (Shaft Horizontal). Microphone is faced to the flat of motor and recedes by 10cm</p>	≤ 50 dB(A)
-----	--------------------------	---	-----------------

6. 电气性能 Electrical characteristics

序号 NO.	项目 Item	测试环境条件 Environmental condition	规格 Specification
6-1	额定电流 Rated current	在额定电压及标准负荷（振子）下，5 秒后读数。 Read the data at rated voltage and rated load(eccentric weight)after 5S.	85mA Max
6-2	额定转速 Rated speed		14000 \pm 2500 r. p. m
6-3	堵转电流 Stall current	在额定电压及标准负荷（振子）下，2 秒后读数。 Read the data at rated voltage and rated load(eccentric weight)after 2S.	95mA Max
6-4	起动电压 Starting voltage	在额定负载（振子）下电枢的任意位置。 At rated load (eccentric weight) any position of rotor.	2.3V DC Max
6-5	端子阻抗 Terminal resistance	在 20 \pm 2 $^{\circ}$ C 下 At 20 \pm 2 $^{\circ}$ C	30.0 Ω \pm 6. 0 Ω
6-6	绝缘电阻 Insulation resistance	在 50V 直流下，导线和机壳间 At DC 50V between lead wire and case.	1M Ω Min

7. 信赖性试验 Reliability Test

序号 NO.	项目 Item	试验条件 Test condition	判定基准 Requirements
7-1	寿命测试 Life test	电压/Voltage: 2.7VDC 负荷/Load: 振子/ eccentric weight (R1.6 T=3.4 约 0.27g) 温度/Temperature/20±2℃ 相对湿度/Relative humidity: 60~70%RH 将马达固定在试验台上(轴向)/Lock the motor in a test fixture(Shaft horizontal) 试验方法 1/Test mode1: 连续运转至少 10 小时/10hrsnet running time 试验方法 2/Test mode2: 一个周期, 开 2.5 秒, 关 2.5 秒; 共 200000 个周期/1cycle, 2.5sec ON, 2.5sec OFF; 200000 cycles totally	在常温常湿下放置 4h 后, 马达应符合项 8-1、8-2 的要求。 After 4 hours exposure in ordinary temperature and humidity, Motors shall be approved as specified in item 8-1、8-2.
7-2	低温放置 Low temperature storage	温度/Temperature: -40±5℃; 时间/Time: 96h 湿度/Humidity: 常湿/ Ordinary Humidity	在常温常湿下放置 4h 后, 马达应符合项 8-1、8-2 的要求。 After 4 hours exposure in ordinary temperature and humidity, Motors shall be approved as specified in item 8-1、8-2.
7-3	高温放置 High temperature exposure	温度/Temperature: +85±5℃; 时间/Time: 96h 湿度/Humidity: 常湿/ Ordinary Humidity	After 4 hours exposure in ordinary temperature and humidity, Motors shall be approved as specified in item 8-1、8-2.
7-4	湿度测试 Humidity test	温度/Temperature: +40±5℃; 时间/Time: 96h 湿度/Humidity: 90±5%RH	After 4 hours exposure in ordinary temperature and humidity, Motors shall be approved as specified in item 8-1、8-2.
7-5	振动 Vibration	全振幅 /Displacement :1.5mm (p-p) 频率/Frequency:10 to 55Hz 周期/Period :20min范围内 (10~55~10Hz) /20 Minutes log sweep (10~55~10Hz) 方向/Direction:x、y、z 时间/Time:每 2h/Each 2 hours	测试结果应符合项 8-1、8-2、8-3 的要求。 After the test motors shall be approved as specified in item 8-1、8-2、8-3.

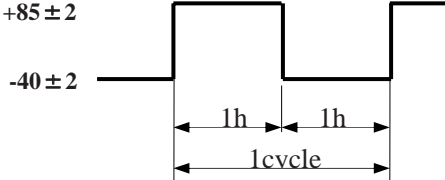
7-6	热冲击试验 Thermal Shock test	温度Temperature : $-40^{\circ}\text{C} \sim 85^{\circ}\text{C}$ 时间Time: 2h 循环周期数Circle cycle: 30cycles 	测试结果应符合项 8-1、8-2 的要求。 After the test motors shall be approved as specified in item 8-1、8-2.
7-7	跌落试验 Drop test	方向Direction: x,y,z 高度High: 1.5m 跌落次数: 每个方向各 2 次 Times: 2 times each direction 试验状态: 将电机放在重约 100 克的刚性较好的塑料盒子里, 自由地跌落至混凝土地面上 Test state: The motor is set into a rigid cubic plastic housing approximately weight 100g and fall free on the concrete floor	试验结束后, 电机应满足 8-1、8-2、8-3 的规定 After having finished the test, the motor should conform to the requirements of the items 8-1、8-2、8-3.

8. 信赖性试验后的要求 Requirement After Reliable Test

序号 NO.	项目 Item	规格 Specification
8-1	额定转速 Rated speed	初始值 $\pm 30\%$ Initial data $\pm 30\%$
8-2	额定电流 Rated Current	初始值 $\pm 35\%$ Initial data $\pm 35\%$
8-3	起动电压 Starting voltage	$\leq 2.3\text{V}$

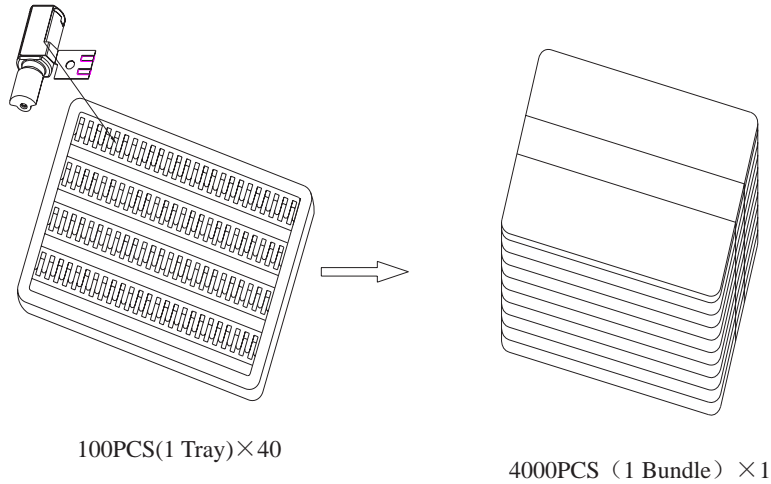
9 包装 Packing
**马达包装
Pack drawing**

包装试验要求/ Package Test Requirement:

标准/ Criterion:

1. 整箱重量小于等于9kg的, 跌落高度设定为75cm.
/ The weight of the whole carton less than 9kg, the dropping height is 75cm.
2. 整箱重量大于9kg但小于等于23kg的, 跌落高度设定为60cm.
/ The weight of the whole carton more than 9kg and less than 23kg, the dropping height is 60cm.

试验方法/Test Methods:

跌落要求为六面三棱一角./Dropping requirement is 6 faces, 3 arris, 1 angle.

六面: 先从最大两面跌, 然后是中间大小的两面, 最后跌最小的两面, 一共六次。

/ 6 faces: First dropping with two biggest faces, then dropping with another two middle faces, at last dropping with two smallest faces, once per face, total 6 faces.

三棱: 指任选三条同一角的棱, 跌落秩序: 最长棱, 中间长度, 最短的, 一共三次。

/ 3 arris: Choose any 3 arris which make up of the same the angle, the dropping sequence is the longest arris, middle arris, shortest arris. Total 3 times.

一角: 指上一步三条棱所组成的角, 跌落一次。

/ 1 angle: Point to the angle which is made up with the 3arris in the above step, Dropping for 1 time.

判定基准/ Judgement Criterion:

经过跌落试验后, 产品外观、性能无不良。

/ After drop test, no evidence of damage on the appearance and performance.

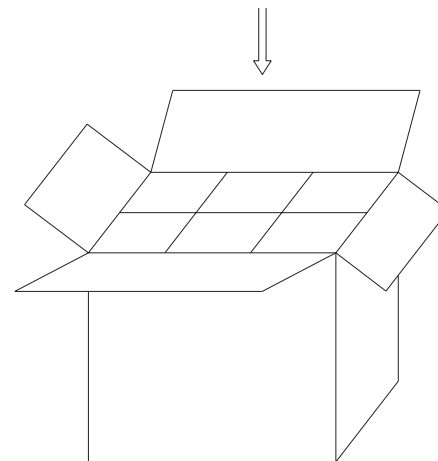

Remarks:

4000PCS/CTN: 25.5cm × 22cm × 21.5cm

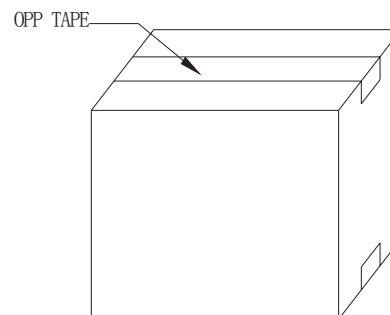

10.注意事项 CAUTIONS**1) 使用容差 ALLOWABLE RANGE FOR USE**

注意电压及电流的使用范围，并且在本标准规定情况下使用电机，否则将相应降低电机的使用寿命和性能。

Pay attention to voltage and current ranges for use ,and use the vibration motor in the condition accordance with this specifications ,or the life and performance should be considerably reduced.

2) 移动电机 MOVE YOUR MOTOR

拿电机时，应轻拿轻放，应尽可能地利用外壳部分

请勿将其跌落或加以超过 5 公斤的压力。否则会引起电机的外部形态和电气特性的改变Please deal with the motors gently, you should make use of the outer case as possible as you can. Do not press the product with more than 0.5 kgf or drop it. It can cause the transformation of performance or external appearance.

电机在运输过程中应小心轻放，避免严重碰撞敲击引起的电机机身和性能受损。

Please lay the motors carefully in transportation to avoid any serious damage to the motor body or its electric function because of collision.

3) 储存 STORAGE

储存温度：-40℃~85℃

储存湿度：0%RH~95%RH

避免放置在高温、潮湿的环境中。

Storage temperature: -40℃~85℃

Storage relative humidity: 0%RH~95%RH

Avoids storing in high temperature、high humidity

马达应适当的操作、储存和运转环境中均不可存在腐蚀性气体。例如：H₂S、SO₂、NO₂、CL₂等。另外存储环境中不可有诸如硅、氰、甲醛水和苯酚等能放射出腐蚀性气体的物质，在电机的机械构造或装置中，如果存在腐蚀性气体，那么这会引起马达不运转。

For proper operation. storage and operating environment must not contain corrosive gases. For example H₂S. SO₂. NO₂. CL₂. etc. In addition storage environment must not have materials that emit corrosive gases especially from silicon. cyanic. formalin and phenol group. In the mechanism or the set. existence of corrosive gases may cause no rotation in motor.

4) 使用电机 HANDLING OF MOTOR

小心拿取、使用。

避免放置在磁性物体附近或接触其表面，这将影响其功效。

注意操作环境，尤其注意若铁粉被磁铁吸附，将出现噪音问题，降低使用寿命

-to handle and hold the vibration motor case softly.

-do not bring magnetized object near or contact with the surface of motor to avoid of performance being deteriorated.

-pay attention to the handling and working environments of motor, because such objects as iron powder if attracted by motor magnet, will cause noise characteristic deterioration, thus reducing the reliability.

请勿靠近磁体或有磁场的装置存放或运行电机

Please do not operate or store the motor near magnet or magnetic devices.

请在 6 个月内使用，请不要在高温、低温、高湿环境下存储。在使用和打开马达外包装时请避免水气凝结。

Make arrangement to limit the storage period to 6 months or less. Please do not store motor in high temperature. Low temperature. high humidity environment. Condensation of atmosphere must be avoided in motor usage or opening the packaging of the motor.

5) 电机接线 **CONNECTION YOUR MOTOR:**

不论使用任何方式将您的电源连接到您的电机，请注意不能用过大的力或过高的温度，否则会造成电机内部零件变形。

Whatever means you are to use to connect your supply to your motor please take care not to use so much force or heat that you cause distortion to components inside the motor.

6) 过负荷 **OVERLOADS:**

请通电后不要长时间堵住机轴，并且马达转动时不要触碰振子。

Please don't stall the shaft for a long time after powering, and not to touch the weight when motor is rotating.

7) 危险环境 **HAZARDOUS ENVIRONMENTS:**

我司电机在正常环境中的抗腐蚀能力是符合要求的，但机壳上有少许区域存在的裸露金属对腐蚀比较敏感，因此未经咨询请不要在腐蚀环境中储存或使用电机。

The degree of protection against corrosion on **Vybronic** motors is satisfactory only for normal environments. There are small sections of the housing in which some bare metal is exposed and is susceptible to corrosion. It is advisable not to store or use motors in corrosive environment without consultation with **Vybronic**.

8) 其它说明 **OTHER**

马达轴向间隙处不应有杂物（如颗粒、纤维物、头发、胶带、胶水等）

There should be no sundries (such as grain, fibre, hair, small tape, glue etc.) in the shaft end play.

9) 请谨记 **ALWAYS REMEMBER**

Vybronic拥有一支专业的技术支持团队，致力于解决我们的电机在新的产品或新的应用中出现的问题，我们乐意与您建立良好的合作关系，我们乐意为您解决使用中遇到的各种问题。

that **Vybronic** has a professional technical support team for the solution of problems on our motors that used in new products or new applications. We are proud of our good working relationship with our customers and we will be most pleased if we can assist you to find a solution to any problem that you may encounter.

11. 附件 **ATTACHMENT**

1) 电机外形图 Motor Outline Drawing

2) 软板图纸 FPC OutlineDrawing

1. RATED VOLTAGE: 2.7V
2. STALL CURRENT: 95mA (max)
3. RATED CURRENT: 85mA (max)
4. STARTING VOLTAGE: 2.3V (max)
5. RATED SPEED: 14000±2500RPM

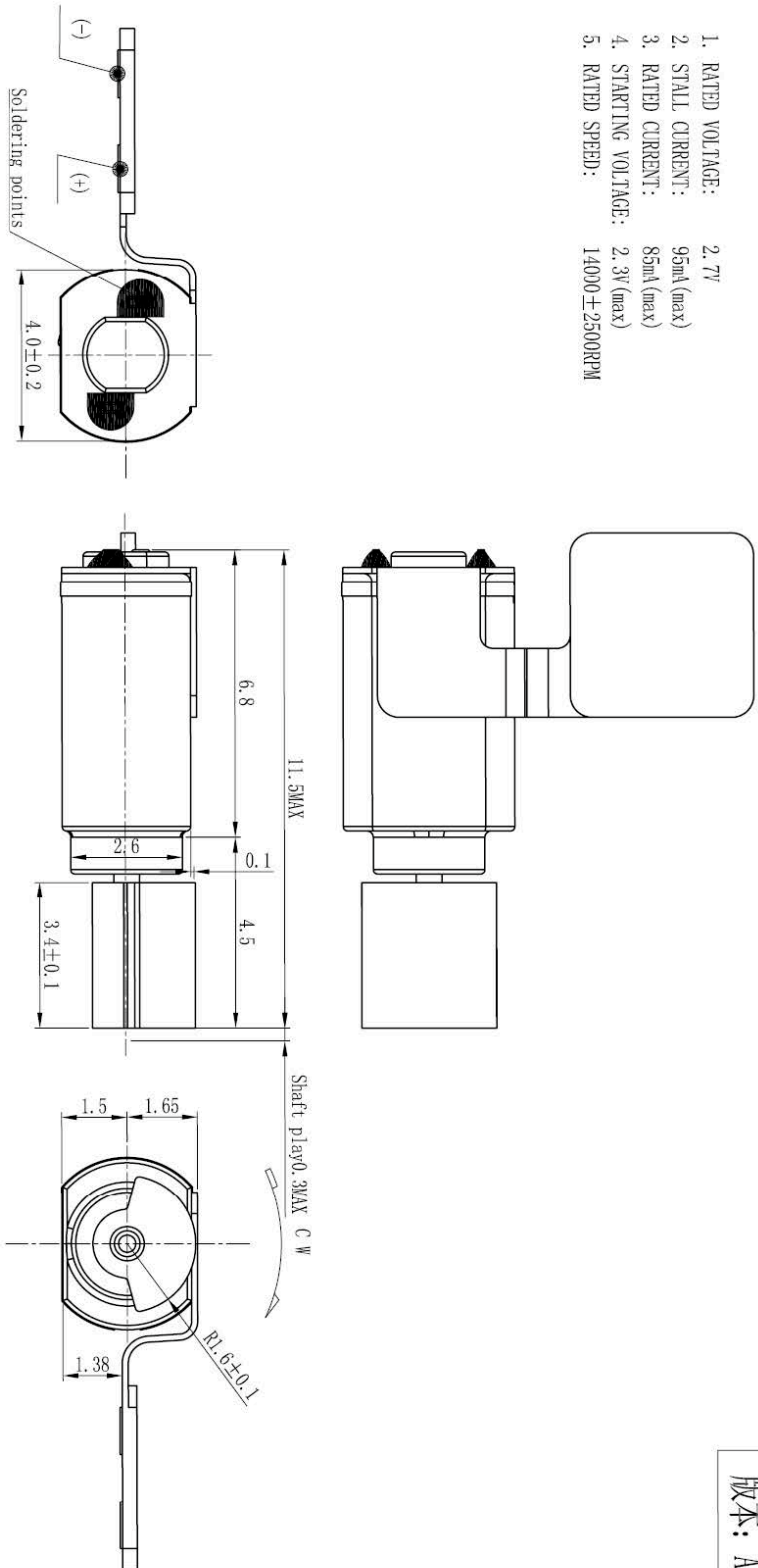

版本: A/0

技术要求:
1. 未注公差尺寸: ±0.2

借 (通) 用件 登记
描 图
描 校
底图总号
签 字
日 期

设计	处数	更改内容	标准号	签字	日期
制图			审定		
校核			批准		
工艺			日期		

图样标记	重量	比例
共 张		7:1
第 张		

Vybronic	
外观图	
VZ30C1T8280002	

借(通)用 件 登 记	
旧底图总号	
底图总号	
卷 字	
日 期	
设计员	
日期	

版本: A/1

技术要求

1. 焊盘厚度0.025mm, 镀层采用电镀金
2. 未注公差按GB1804-m
3. 镀金面先洁无异物。

材料:		图样标记		重量		比例	
设计	处数	更改文件号	标准化	签字	日期		
制图			审定				
校对			批准				
工艺			日期				